

Reg. No. : 

--	--	--	--	--	--	--	--	--	--	--	--

**Question Paper Code : 60061**

B.E./B.Tech. DEGREE EXAMINATIONS, APRIL/MAY 2022.

Second Semester

GE 3251 — ENGINEERING GRAPHICS

(Common to : All Branches (Except Marine Engineering))

(Regulations 2021)

Time : Three hours

Maximum : 100 marks

Answer ALL questions.

(5 × 20 = 100)

1. (a) An inelastic string of 150 mm length has its one end attached to the bottom most point of the circumference of a circular disc of 40 mm diameter. Draw the curve traced by the other end of the string when it is completely wound around the disc keeping the string always tight. Name the curve obtained. Draw the tangent and normal to the curve at a point 100 mm from the Centre of the disc. (20)

Or

- (b) Draw the front, top and left side views for the figure shown. (20)

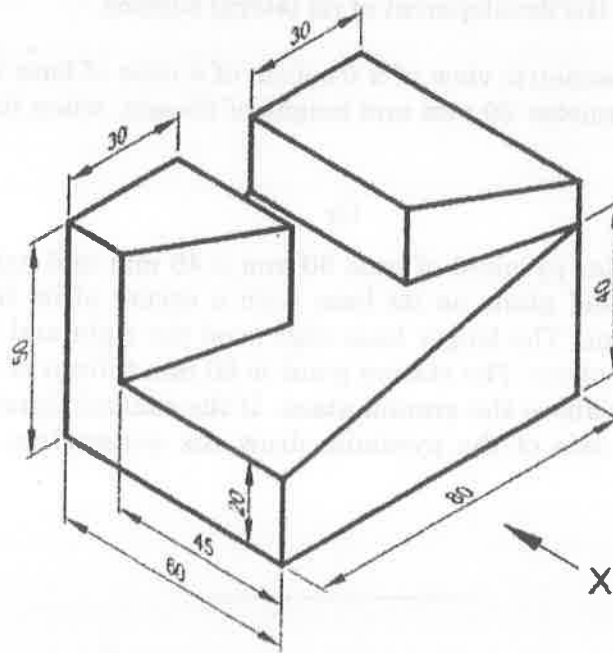

2. (a) The top view of a line PQ has a length of 100 mm and makes an angle of  $35^\circ$  with the horizontal. The end Q is in the HP and end P is in the VP and 50 mm above the HP. Draw the projections of the line and find its true length and true inclinations with the reference planes. Also locate the traces. (20)

Or

- (b) A semi-circular plate of 50 mm diameter rests on its diameter on the HP inclined at  $45^\circ$  to the VP. Draw the projections of the plane when its surface is inclined at  $30^\circ$  to the HP. (20)
3. (a) Draw the projections of a cube of edge 40 mm resting on one of its corners on the H.P with a solid diagonal perpendicular to the V.P. (20)

Or

- (b) A pentagonal pyramid of base side 30 mm and axis 60 mm rests on an edge of its base on the ground so that the highest point of the base is 20 mm above the ground. Draw its projections when a vertical plane containing the axis is inclined at  $30^\circ$  to the V.P. (20)
4. (a) A cone of base diameter 50 mm and axis height 70 mm is resting on HP on its base. It is cut by a section plane which is parallel to one of its extreme generators so that the true shape of the section is a parabola with base 45 mm. Draw the front view, sectional top view and true shape of the section. (20)

Or

- (b) A hexagonal pyramid of base side 30 mm and axis 70 mm is resting on the ground with a side of base parallel to the V.P. A circular hole of diameter 30 mm is cut through the faces of the pyramid such that axes of the hole and the pyramid intersect at right angle and 25 mm above the base. Draw the development of its lateral surface. (20)
5. (a) Draw the isometric view of a frustum of a cone of base diameter 60 mm, top face diameter 30 mm and height of 55 mm, when its axis is vertical. (20)

Or

- (b) A rectangular pyramid of base  $30 \text{ mm} \times 40 \text{ mm}$  and height 50 mm rests on the ground plane on its base with a corner of its base touching the Picture Plane. The longer base edge is on the right and inclined at  $30^\circ$  to the picture plane. The station point is 60 mm in front of the picture plane and 70 mm above the ground plane. If the central plane is 30 mm on the left of the axis of the pyramid, draw the perspective projection of the pyramid. (20)